

Staircase configurations

Richard Burbidge stair balustrading has been designed for use in the majority of staircase configurations. No staircase need present a difficult problem if the components are used and installed in the correct manner. To assist we have illustrated the most popular/standard 'start', 'turn' and 'landing' options in the construction and assembly of feature staircases. The individual components are identified on each illustration and each is accompanied by a simple plan.

For full range details/timber types please refer to the Richard Burbidge Trade Price List.

All diagrams are based on staircases with individual rises of 200mm and domestic handrail heights of 900mm for both stairs and landings (1992 Building Regulations, part K).

Where applicable Bracket Fix options are denoted by, for example, B.Fix.N160. Standard cut-off points/setting out heights of newel bases for Bracket Fix stair balustrading used in non standard situations will not apply (see pages 22-23 for Bracket Fix System details). Further advice on all systems is available by contacting our technical advisers on 01691 678212.

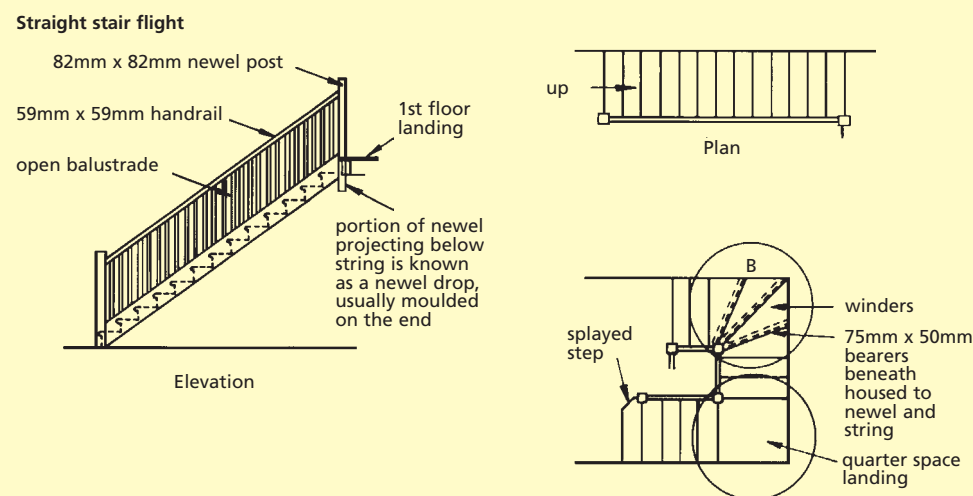
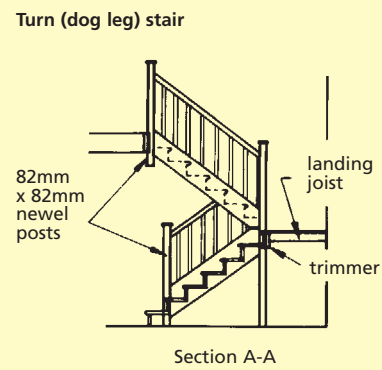
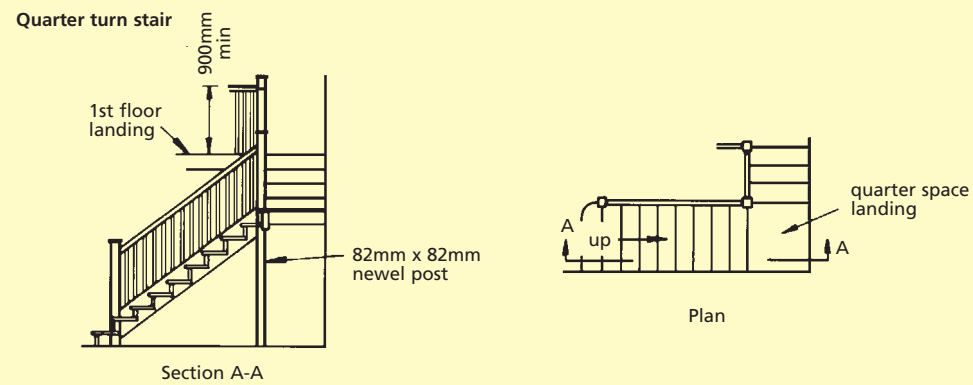
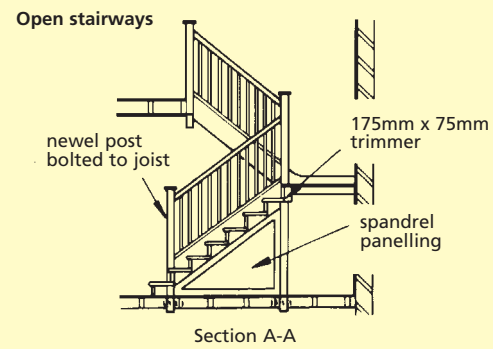

BOTTOM OF FLIGHT

DOMESTIC STAIRCASES - ALL DIAGRAMS ARE BASED ON STAIRCASES WITH INDIVIDUAL RISES OF 200mm AND DOMESTIC HANDRAIL HEIGHTS OF 900mm FOR BOTH STAIRS AND LANDINGS

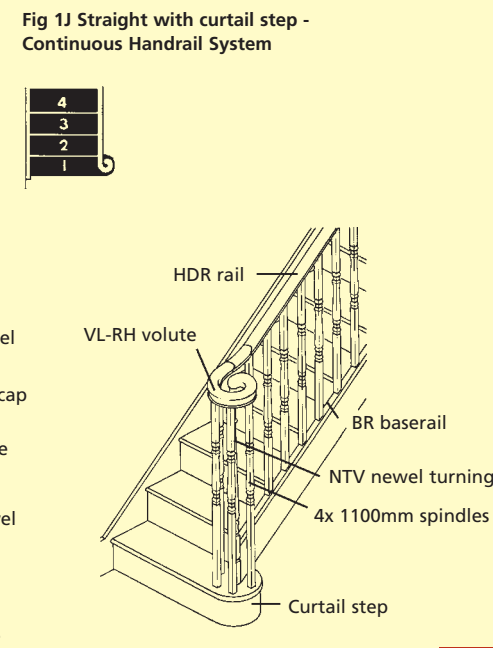
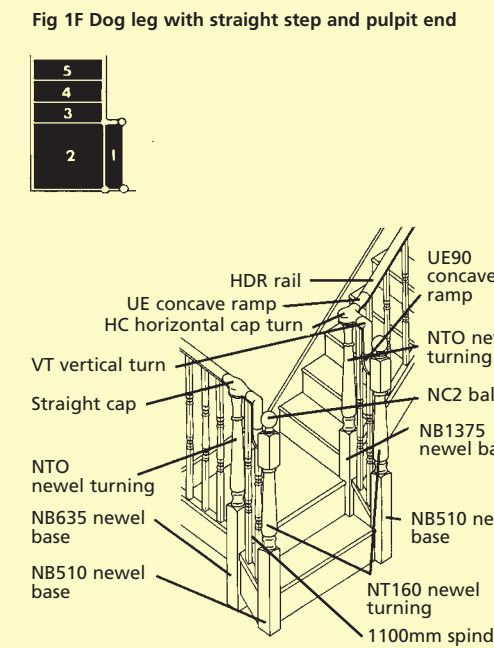
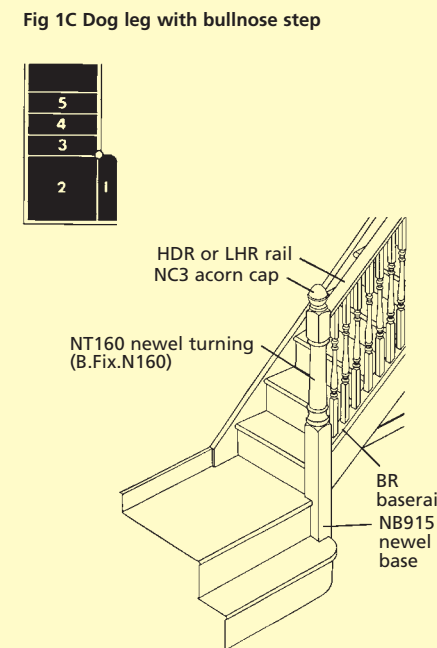
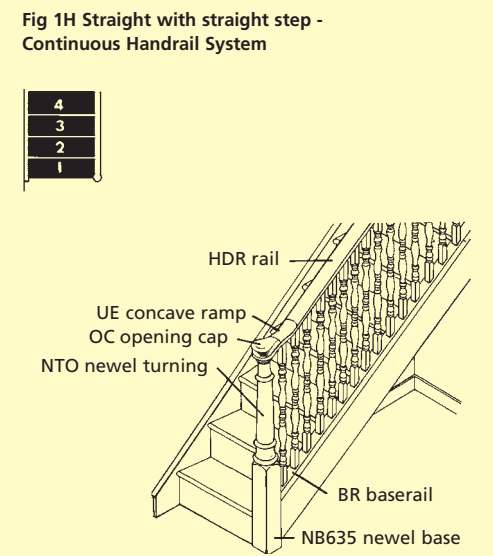
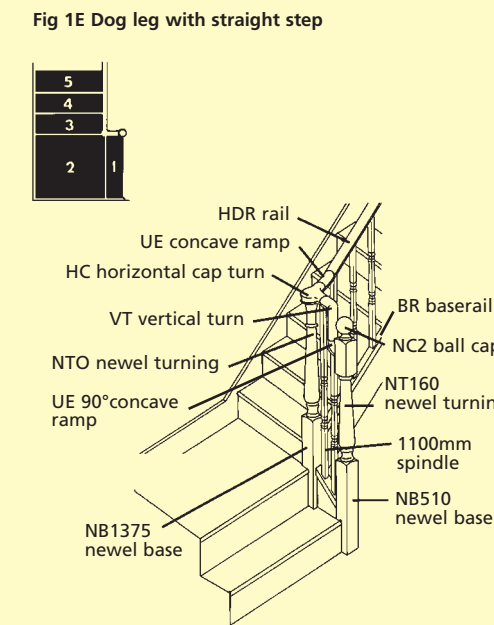
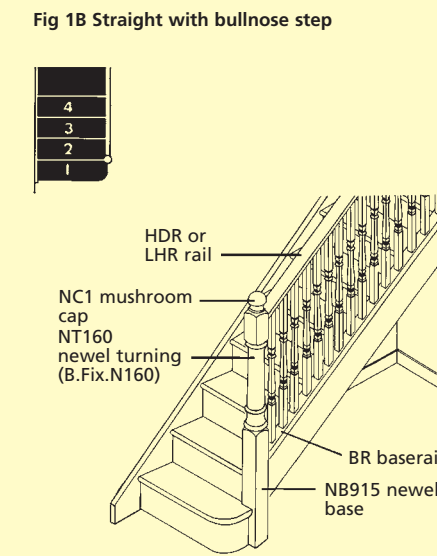
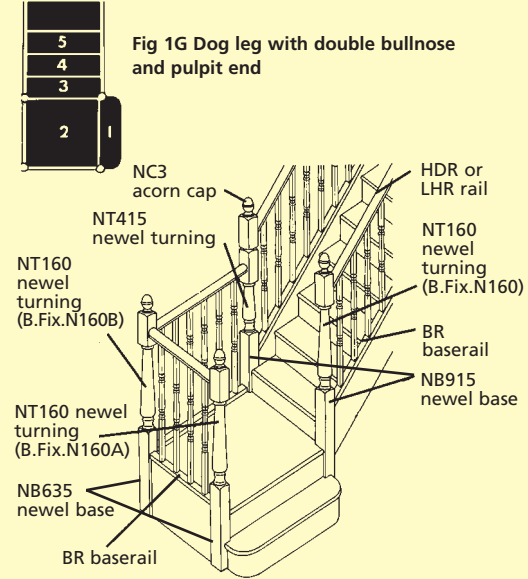
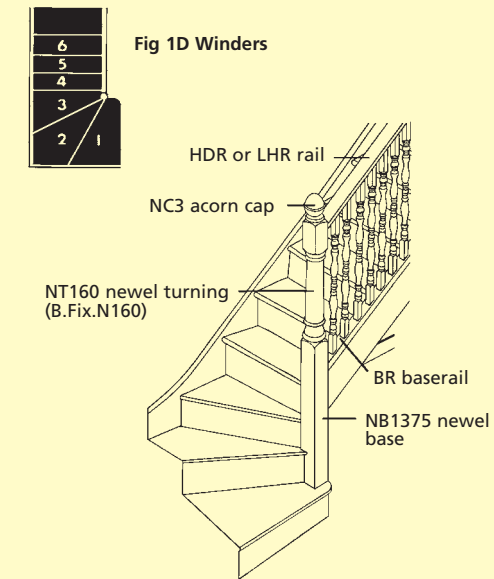
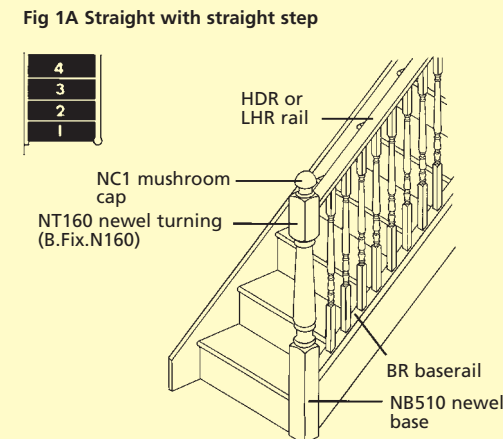

INTERMEDIATE LANDINGS/WINDERS

Fig 2A Quarter turn with landing

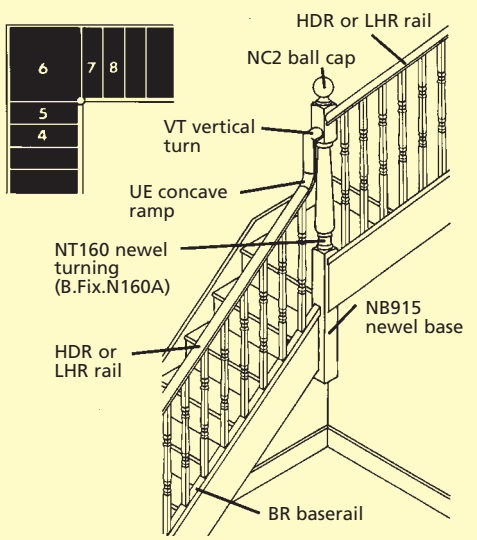

Fig 2B Quarter turn with landing

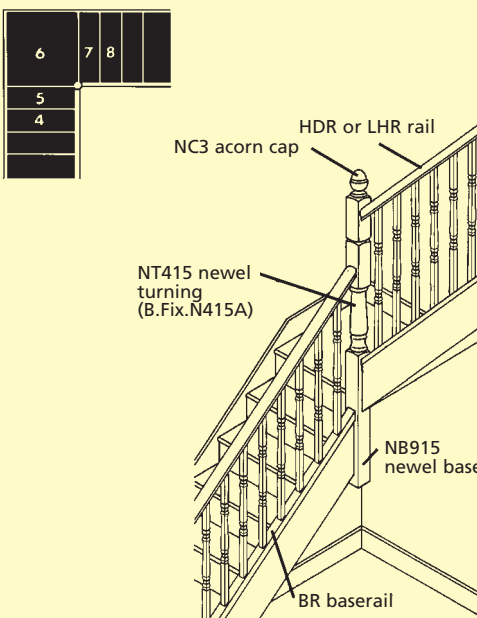

Fig 2C Quarter turn with three winders

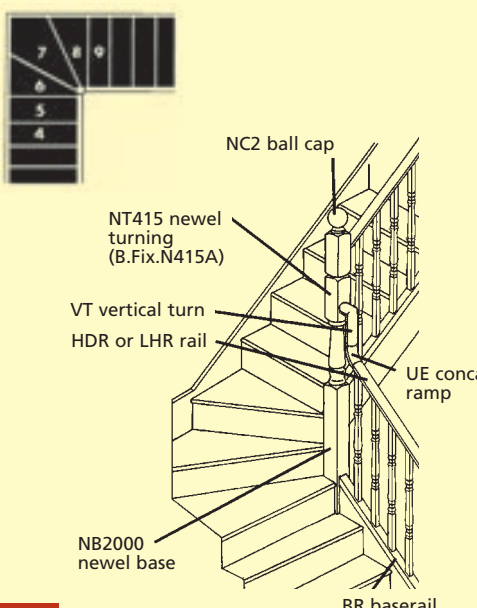

Fig 2D Quarter turn with three winders

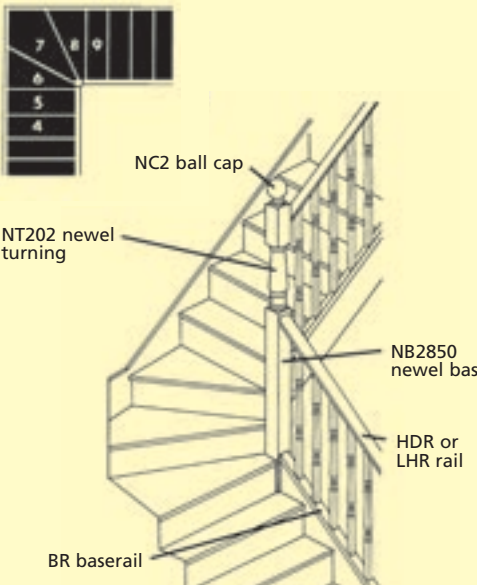

Fig 2E Quarter turn with four winders

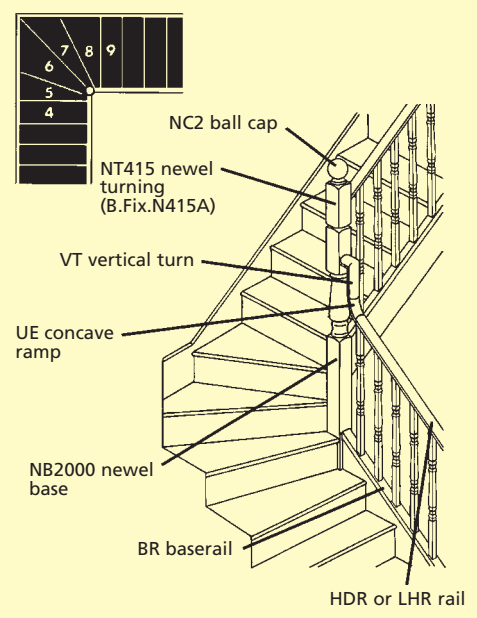

Fig 2F Half turn with landing - minimum distance between centres of strings 82/90mm, 2 newel bases side by side 82 or 90mm section

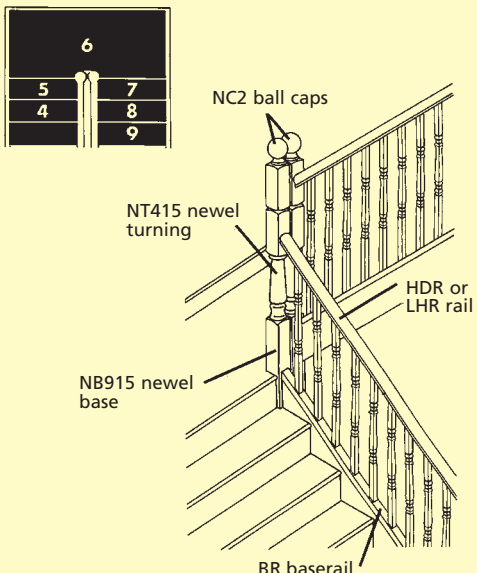

Fig 2G Half turn with landing

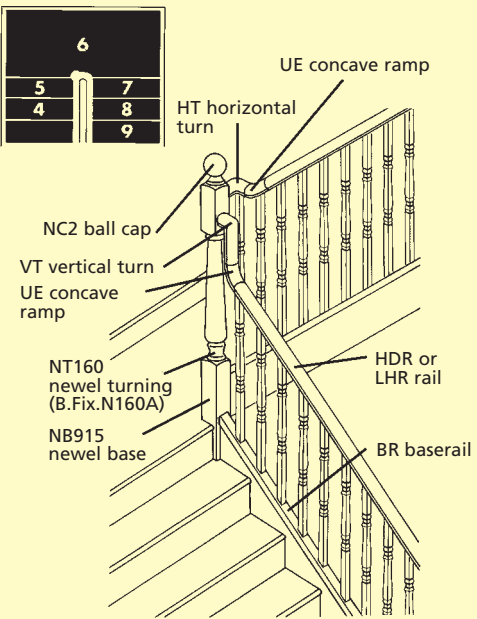

Fig 2H Half turn with extended landing

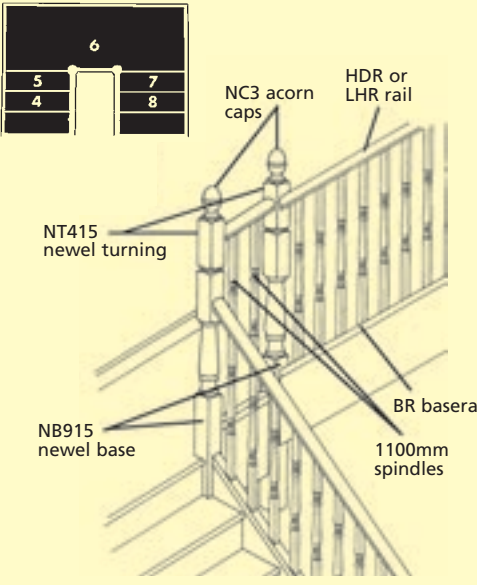

Fig 2J Quarter turn with landing - Continuous Handrail System

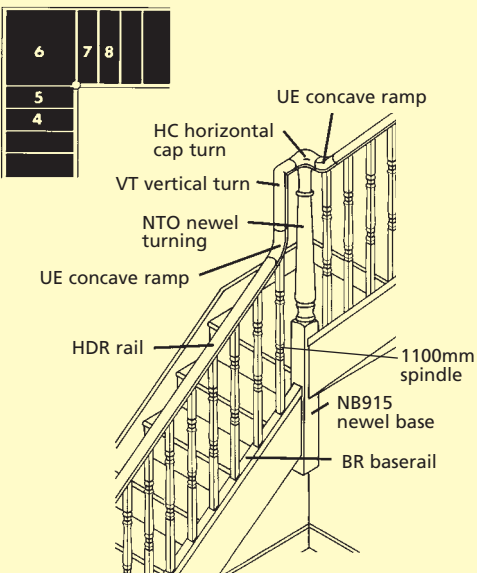
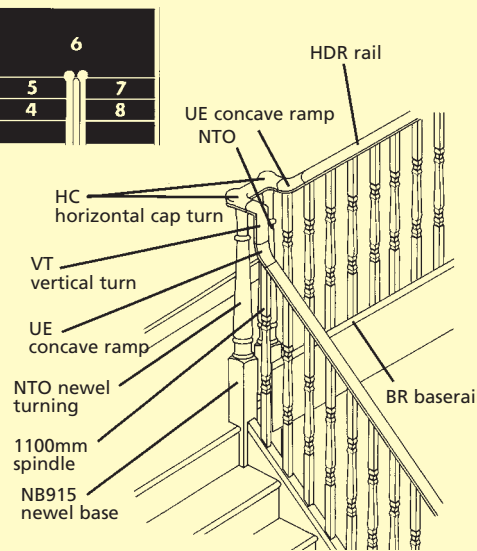

Fig 2K Half turn with landing - Continuous Handrail System minimum distance between centres of strings 150mm



LANDINGS

Fig 3A Top landing with 90° turn

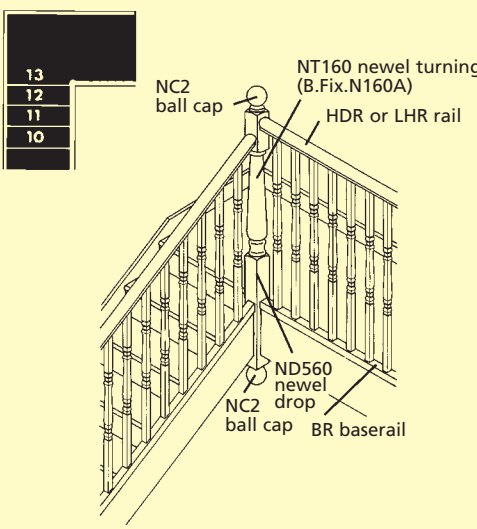

Fig 3B Top landing with 180° turn

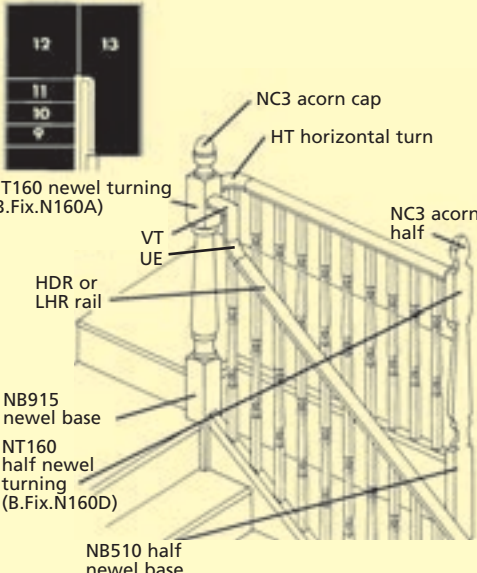

Fig 3C Top landing with 180° turn

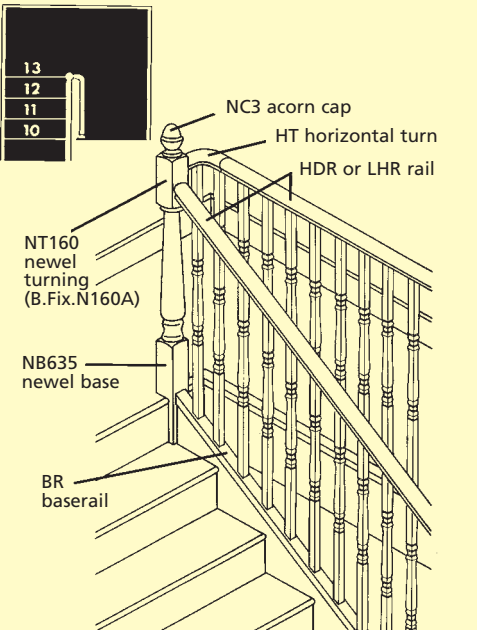

Fig 3D Top landing 180° turn with winders

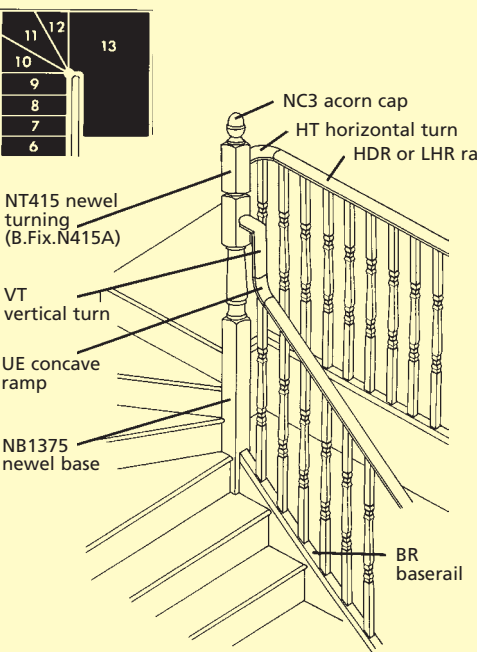

Fig 3E 90° turn with straight rail (without newel)

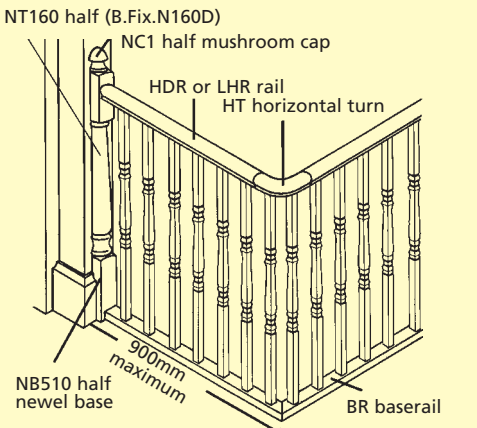

Fig 3F 90° turn with straight rail (with newel)

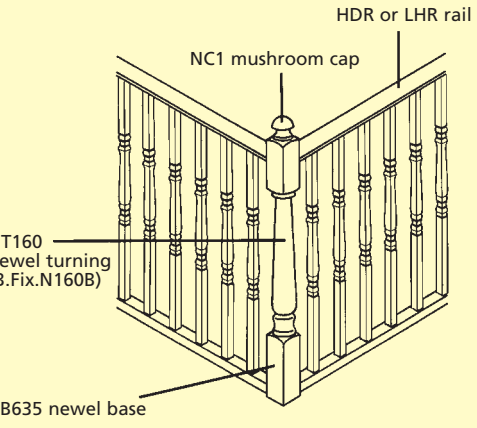

Fig 3G Landing or horizontal balustrading only

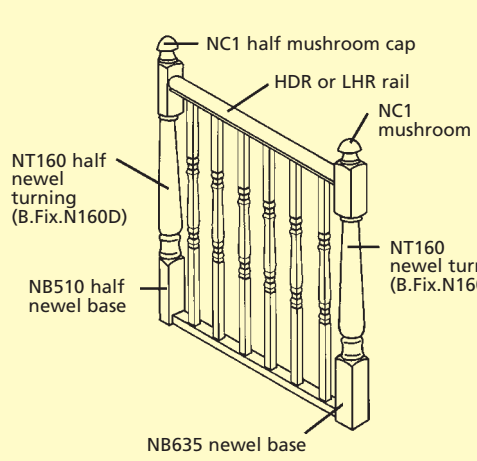

Fig 3H Top landing with 90° turn - Continuous Handrail System

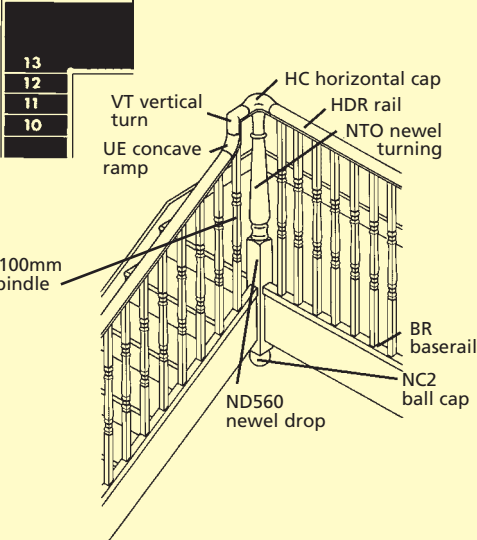

Fig 3J Continuous rail over newel

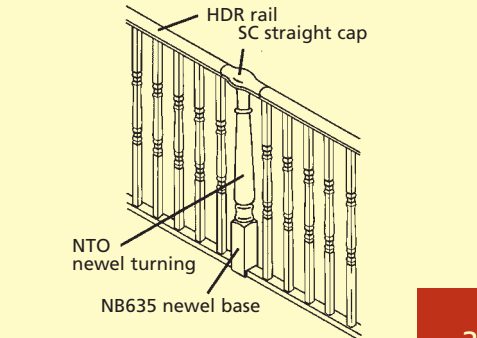

Fig 3K Top landing with 180° turn - Continuous Handrail System

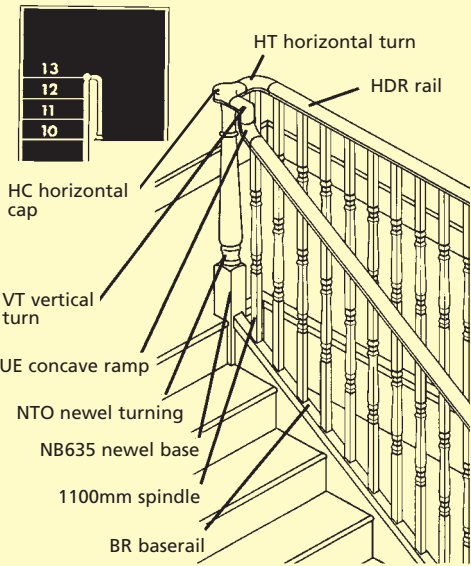
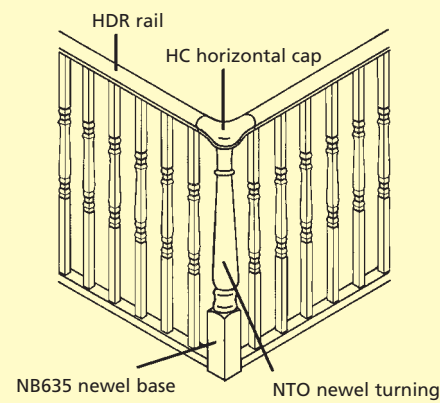

Fig 3L 90° Turn with continuous rail (with newel)



Category C buildings (retail) have a strength requirement of 1.5kN/m, which no timber-based system is likely to comply with. Alternative materials would have to be used in retail situations.

Note - This does not affect balustrading used for aesthetic purposes only in retail situations, eg room dividers, providing they are not guarding a difference in height of more than 380mm.

The following illustrations show Classic Oak stair balustrading in use in non domestic situations with handrails set at 900mm/1100mm.

Fig 4A Straight with bullnose step - Classic Oak

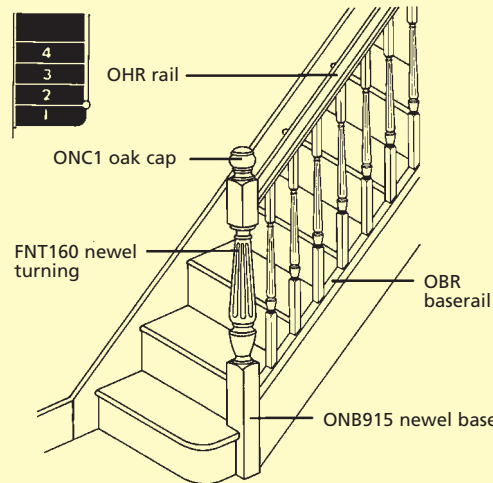

Fig 4B Quarter turn with landing - Classic Oak

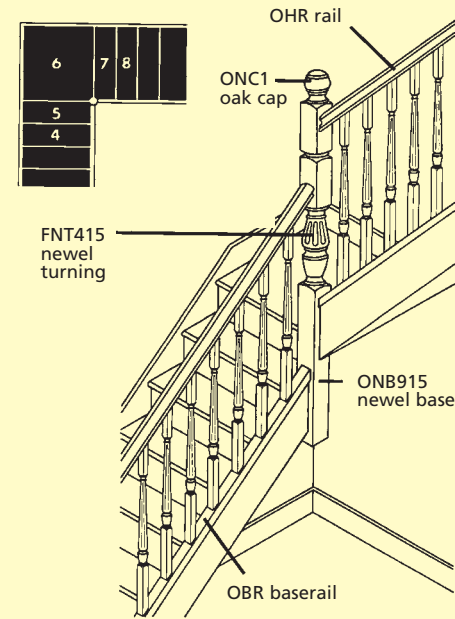
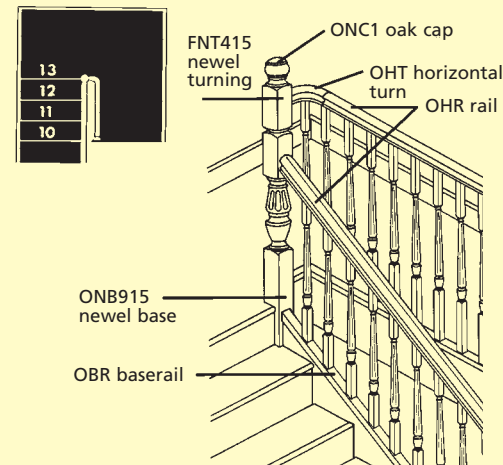

Fig 4C Top landing with 180° turn - Classic Oak



UNUSUAL SITUATIONS

Figures 1 and 2 are suitable for HDR handrail applications

Fig 1 Ceiling lines

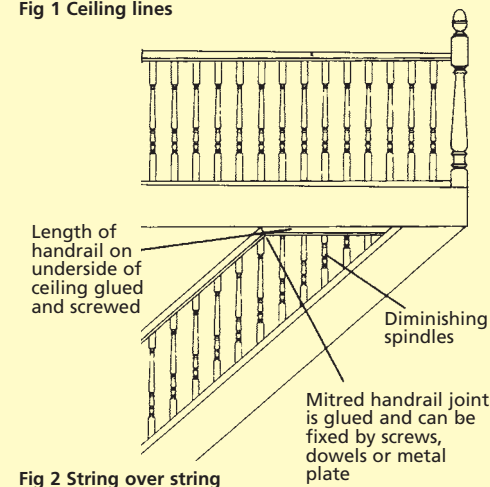

Fig 2 String over string

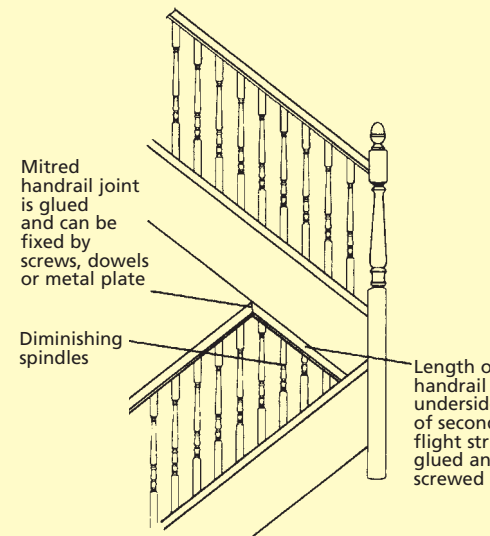
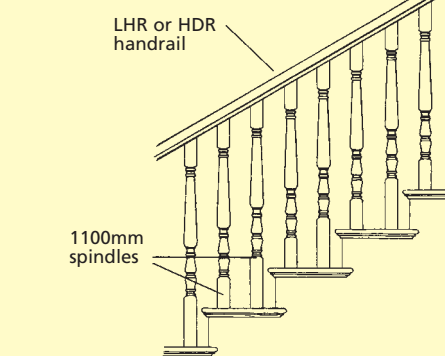

Fig 3 Cut string



CEILING LINE / STRING OVER STRING (Figs 1 and 2)

In these situations we recommend that a length of handrail is run up from the bottom newel to the underside of the ceiling line/string and then a further length of handrail is run along the underside of the ceiling line/string. Where the two handrails meet they should be mitred together. As the spindles reach the underside of the ceiling line/string they will diminish in length, the bottom squares of the spindles should be kept at the same length in order to maintain an aesthetic balance with the pitch of stairs/handrail. Spindles are reduced from the top downwards which sometimes means that you will be cutting into the turn of the spindle. To space, cut the fillets with a coping saw to suit. Spindles and fillets are fixed as normal by gluing and pinning.

CUT STRING (Fig 3)

In this situation use 1100mm length spindles for both the front and back edges of steps. The traditional fixing method is to use a stub tenon joint or, as an alternative, individual lengths of baserail can be screwed directly to the step with the spindles fixed into the baserail as normal. So as to avoid exposed end grain reverse mitre both the front and back faces of the baserail.

FUSION™ CONFIGURATIONS

PLEASE NOTE ALL FUSION™ STAIRPARTS ARE PREFINISHED APART FROM NEWEL BASES

Fig 1A Straight with straight step

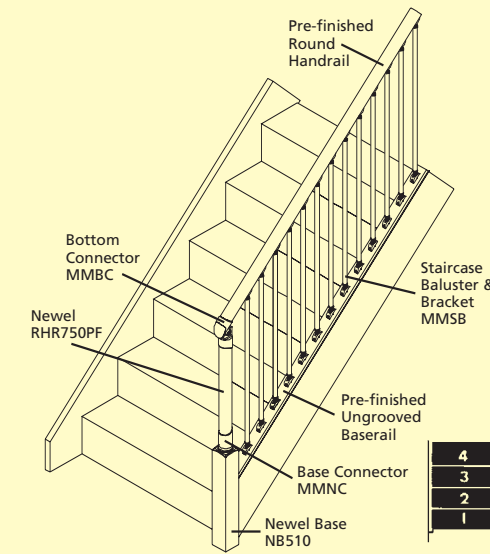

Fig 1D Winders

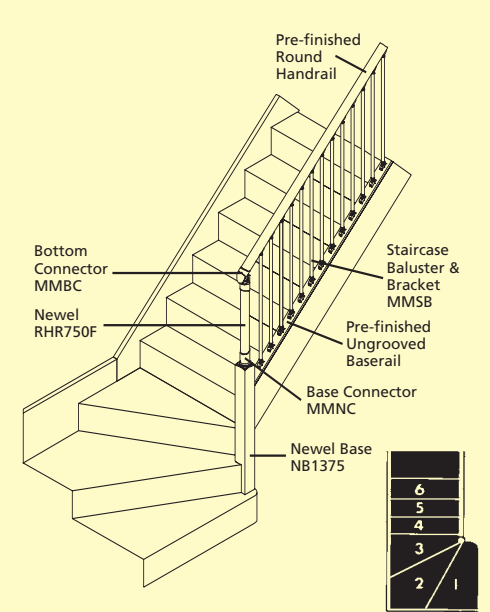

Fig 2B Quarter turn with three winders

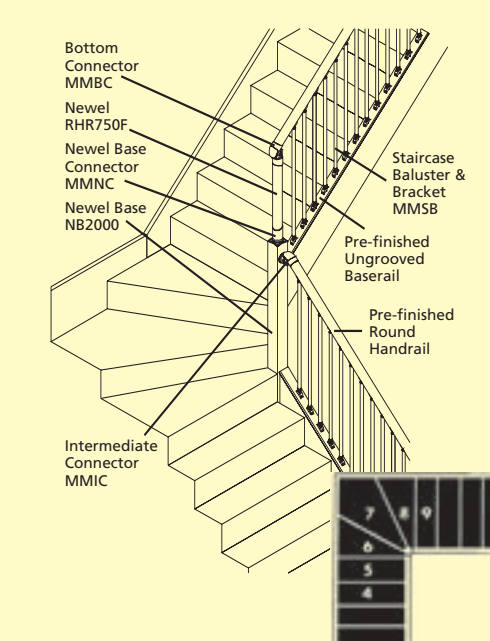

Fig 1B Straight with bullnose step

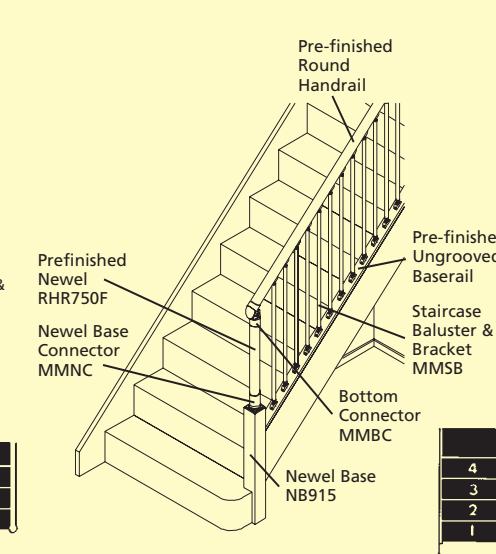

Fig 1E Dogleg with double bullnose and pulpit end

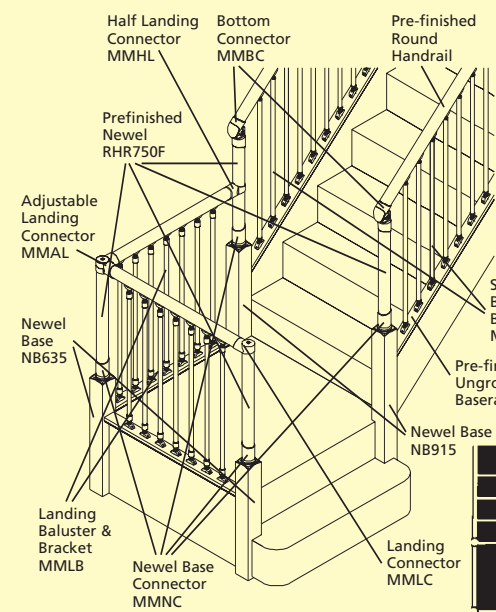

Fig 2C Half turn with extended landing

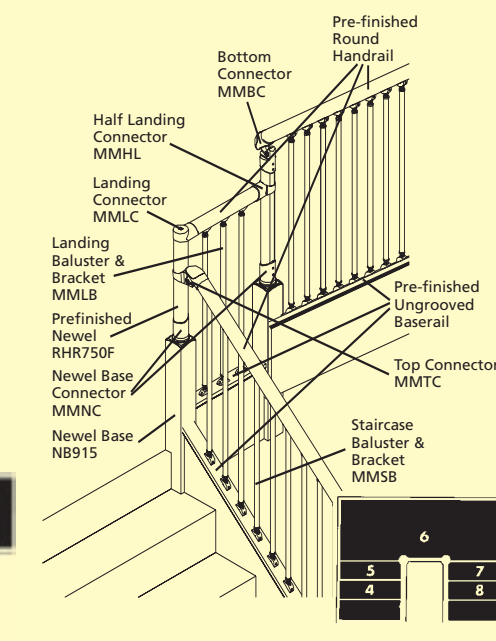

Fig 1C Dogleg with bullnose step

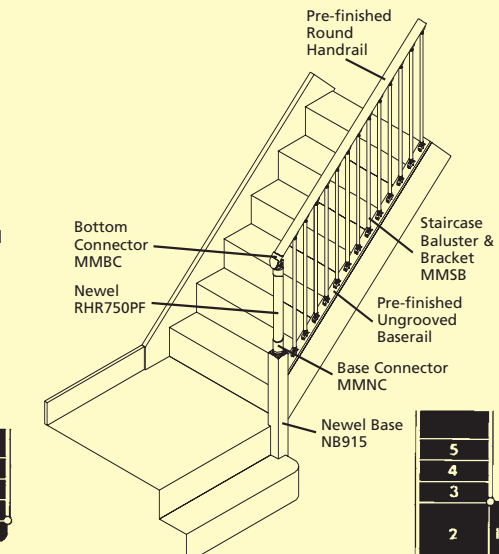

Fig 2A Quarter turn with landing

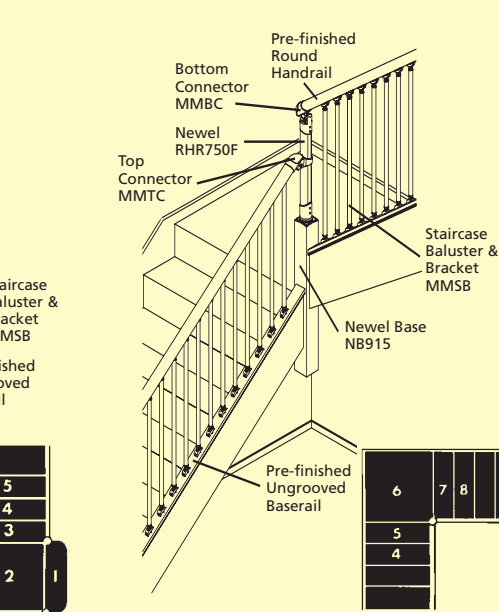
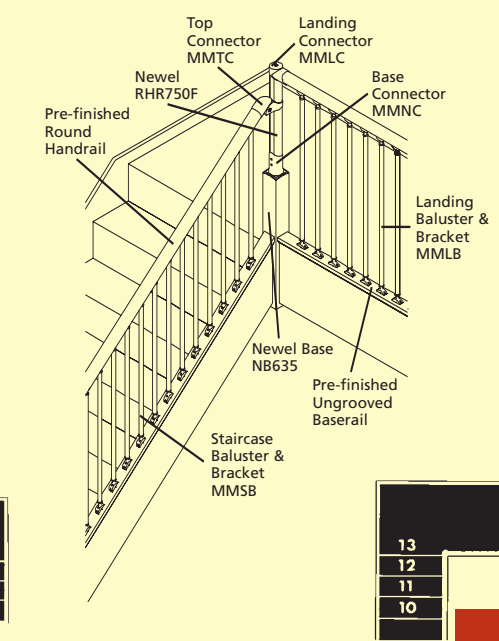

Fig 3A Top landing with 90° turn



NON DOMESTIC STAIRCASES

Richard Burbidge stair balustrading systems are designed primarily for use within domestic houses. However, many non domestic staircases are also enhanced by the use of traditional timber balustrading and this section gives details of suitable products and their application.

Within the 1992 Building Regulations (part K), there are several different categories of building type that fall within the general area of non domestic. The reason for the distinction is that different strength requirements are demanded according to the building's usage, specifically:

- Category A - Factories/warehouses (light traffic)
- Category B - Residential (eg flats, old people's homes, educational, office and public buildings)
- Category C - Retail premises.

In all three of these building types the requirement concerning handrail height differs from that in domestic housing. The minimum handrail heights permitted are 900mm for rake of stairs and 1100mm for landings.

The regulations specify a strength requirement as follows (from above): category A: 0.36kN/m (as per domestic); category B: 0.74kN/m; category C: 1.5kN/m. Further strength requirements are required under B56180 concerning the balustrading's infill (in this case spindles).

Richard Burbidge stair balustrading conforms to the strength requirements for domestic usage and thus can be used for category A buildings (as defined above), taking care to set the handrail height on the landing at 1100mm rather than 900mm.

Note - Richard Burbidge Classic Oak stair balustrading has been tested in accordance with the increased requirements for category B buildings and is suitable for use in those buildings (Straight Handrail system only). We also have additional balustrade systems suitable for non domestic use. For further information please contact our customer services department.

Fig 3B Top landing with 180° turn

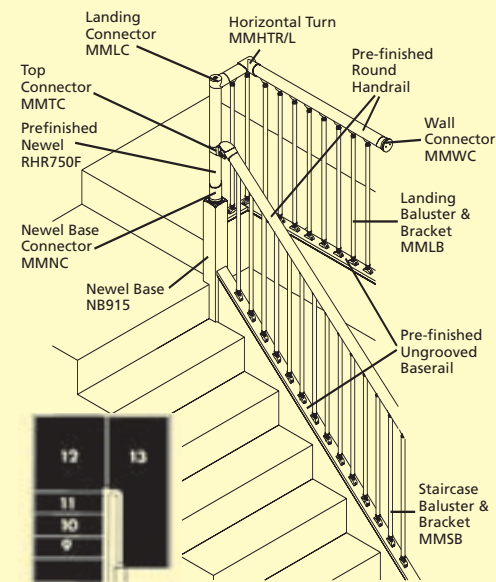

Fig 3C Top landing with 180° turn

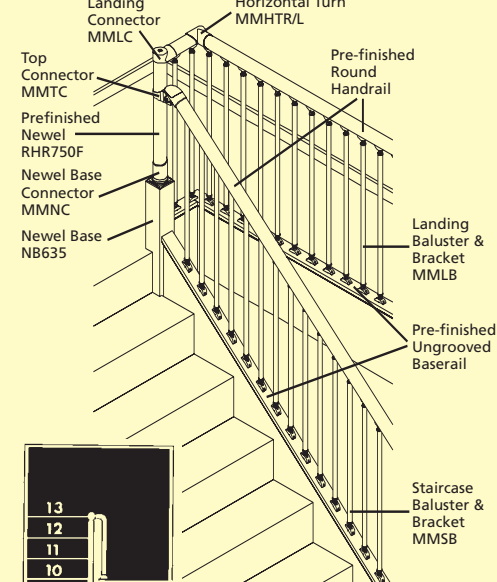

Fig 3D Top landing, 180° turn with winders

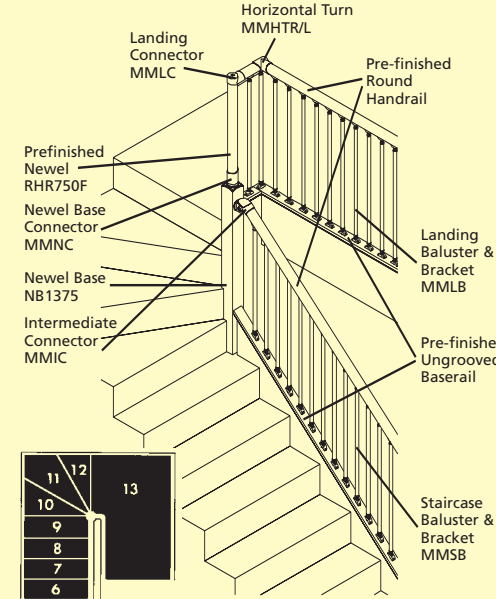

Fig 3E 90° turn with straight rail (with newels)

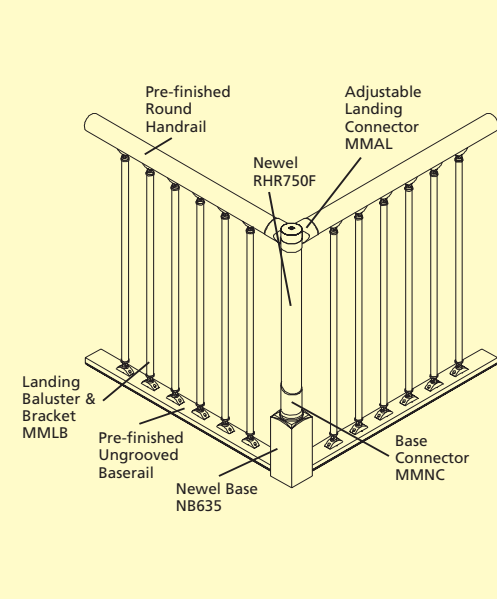

Fig 3F Continuous rail over newel

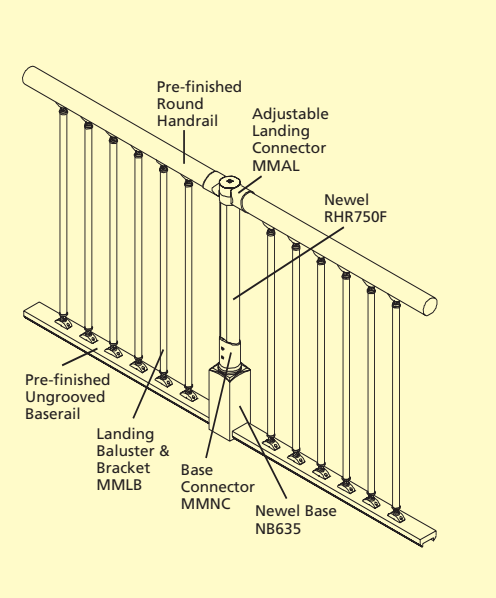
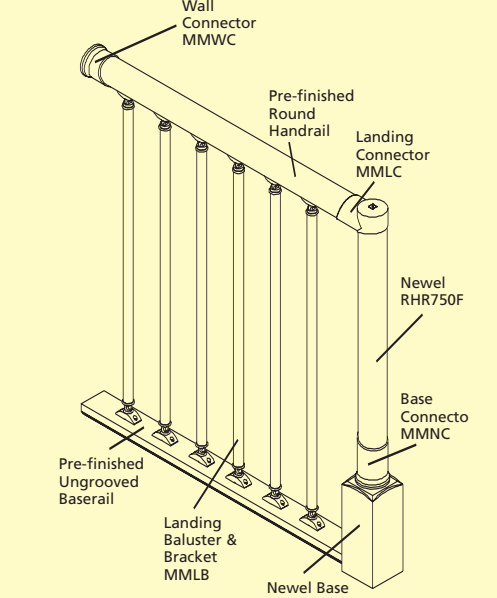
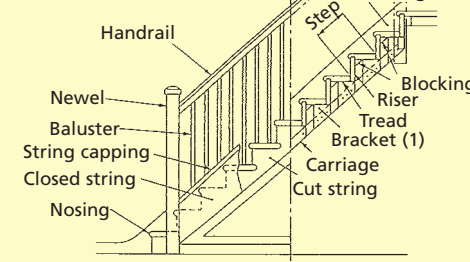

Fig 3G Landing or horizontal balustrading only



STAIR BALUSTRADING TERMINOLOGY

Fig 1 Elevation and section



This glossary of staircase related terminology is by no means exhaustive but does detail the most common and basic terms used in staircase construction and balustrading installation.

Baluster/Spindle: The vertical member, plain or decorative, that acts as the infill between the handrail and baserail (or tread if cut string).

Balustrading: The collective name for the complete assembly of handrails, baserails, newels, spindles and caps.

Bracket Fix: Patented Richard Burbidge Limited system which uses a bracket to fix the handrail to the specially designed newels.

Bullnose Step: Usually at the bottom of the stairs with one or both ends of the step having a quarter circle design.

Closed String: A string with the face housed/trenched to accommodate treads and risers so their profile cannot be seen.

Continuous Handrail: Using straight lengths of handrail connected to handrail fittings and ramps, the handrail flows over the tops of newel turnings creating a continuous run of handrail.

Curtail Step: A decorative shaped step at the bottom of the stairs usually accommodating the volute and volute newel turning of the Continuous Handrail System.

Cut or Open String: A string with the upper edge cut away to the shape of the treads and risers so that their profile can be seen from the side.

Going: The going of a flight of stairs is the horizontal distance between the face of the first and last risers. The individual going of a step is measured from face of riser to face of riser and for domestic use should be a minimum of 220mm.

Newel: Accommodates the strings, handrails and treads/risers of stairs.

Nosing: The edge of the tread projecting beyond the face of the riser and the face of a cut string.

Pitch: The angle between the pitch line and the horizontal.

Pitch Line: The notional line connecting the nosings of all treads in a flight of stairs.

Rake: The pitch of the stairs.

Rise: The rise of a flight is the vertical distance between the floors or landings connected by the flight. The individual rise is the vertical measurement from top of tread to top of tread.

Riser: The board that forms the face of the step. The maximum individual rise for domestic flights is 220mm.

Staircase: The entire structure relating to a stair, comprising steps, treads, risers, strings, balustrading, landings etc.

Stairway/Stairwell: The space/void provided for the stairs.

Step: The tread and riser combined.

String Margin: The distance between the top of the string and the pitch line measured at 90° to the pitch line.

Tread: The top or horizontal surface of a step.

Wall String: The string of a staircase fixed flush with a wall.

Winders: Are radiating steps narrower at one end that are used to change the direction of a stairs through 90° or 180°.

Fig 2 Rise and going

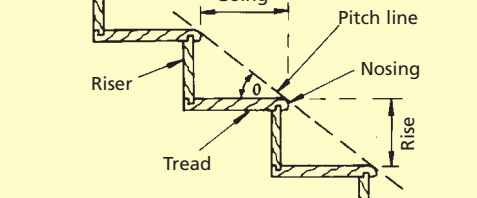

Fig 3 Balustrades and handrails

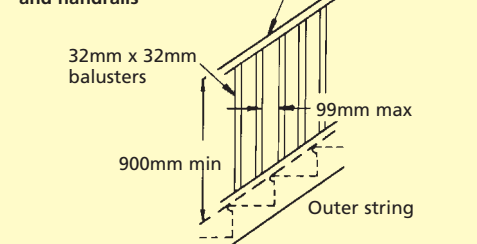
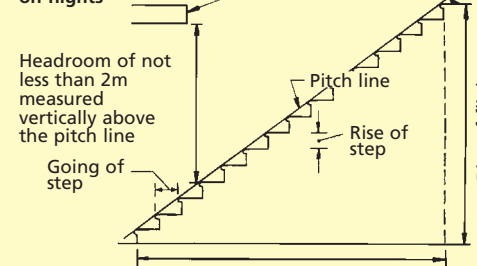

Fig 4 Restrictions on flights



BUILDING REGULATIONS & BRITISH STANDARDS

Approved Document K of the Building Regulations 1992: Stairs, Ramps and Guards gives provisions for stairways in the design and building of stairways which form part of the structure and guidance on the aspects of geometry and guarding of stairs.

BS585 Part 1 1989: Woodstairs covers specifications for stairs with closed risers for domestic use, including straight and winder flights and quarter or half landings. Appendix A of this standard also details the recommendations for the site fixing of stairs.

BS5395 Part 1 1977: Stairs, Ladders and Walkways covers the design of straight stairs.

BS6180 1982: Code of practice for protective barriers in and about buildings.

DEFINITIONS
Private stairs intended to be used for only one dwelling with a maximum rise of 220mm and a minimum going of 220mm. A maximum pitch of 42° is stipulated for domestic stairs.

Institutional and assembly stairs serving a place where a substantial number of people will gather, with a maximum rise of 150mm and a minimum going of 280mm.

Other stairs covers all other types of buildings, with a maximum rise of 190mm and a minimum going of 250mm.

Note - Institutional and assembly stairs plus other, both reference Approved Document M, Access and facilities for disabled people for the maximum permissible rise of stairs providing access for disabled people.

The normal relationship between the dimensions of the rise and going can be expressed as detailed in Approved Document K, which states that twice the rise plus the going (2R+G) should be between 550mm and 700mm.

Pitch the angle between the pitch line (notional line connecting nosings) and the horizontal. The maximum pitch for domestic stairs is 42°, semi-public stairs, eg factories, offices and common stairs serving more than one dwelling, 38° and public stairs, eg places of public assembly, 33°.

Height of handrails Approved Document K states that flights should have a handrail on at least one side if they are less than one metre wide and on both sides if they are wider than one metre. There is no need for handrails beside the bottom two steps of a stairway. Minimum domestic handrail heights of 900mm for both stairs and landings, public handrail heights should be a minimum of 900mm on stairs and 1100mm on landings.

It is also a Building Regulations requirement that no openings in any balustrading should allow the passage of a 100mm sphere.

SUITABILITY FOR USE

Richard Burbidge stair balustrading systems in all timber types have been fully tested by BM TRADA for conformity to domestic requirements as stated in the Building Regulations Part K, 'The guarding should be able to resist a horizontal force of 0.36kN for each metre of length if it guards a private stairs'. In addition, spindles have been subjected to a separate test as stated in BS6180 table 2 column 4(a).

The Richard Burbidge Classic Oak Straight Handrail System has been tested to public strength requirements of 0.74kN.

Richard Burbidge stair balustrading systems were tested using traditional draw-bored mortise and tenon joints (Straight Handrail System), patented universal brackets (Bracket Fix System) and tie-rail bolts/metal fixing plates (Continuous Handrail System). We do not recommend the use of any other fixing method.

Richard Burbidge stair balustrading is manufactured from high quality raw materials complying to BS1186 and are kiln dried ready for immediate internal use. All components are turned or moulded to profile and sanded to a fine finish.

Richard Burbidge Limited is a BSI registered firm ISO9002 and is the first member of the BM TRADA Q Mark Approved Timber Balustrade Scheme (certificate No. 001).

SPECIFICATION - MATERIALS USED

Timber is a natural product and components may vary in colour between pieces.

Pine - *Pinus sylvestris* L.: commonly referred to as European redwood or Scots pine. Creamy white to yellow sapwood with a distinctive yellow/reddish brown resinous heartwood. Ideal for painting, staining and varnishing. Average weight 510kg/m³.

Hemlock - *Tsuga heterophylla* Sarge: Western hemlock, a non-resinous North American softwood. Pale brown, straight grained with a fairly even texture. Can be painted, stained, varnished or polished. Average weight 500kg/m³.

Sapele - *Entandrophragma cylindricum* Sprague: Distributed in West and East Africa. Medium to dark reddish brown heartwood, similar to mahogany in colour. Sapele is characterised by a marked and regular stripe with an interlocked/wavy grain and is fairly close textured. Stains, varnishes and polishes extremely well. Average weight 640kg/m³.

Oak - *Quercus rubra*: American red oak varying in colour from pink to pale reddish brown with a reddish cast. A mostly straight grained and coarse textured timber. Can be varnished, stained, polished and limed to a good finish. Average weight 790kg/m³.

European Beech - *Fagus sylvatica* L.: No colour distinction between sapwood and heartwood, the timber being pale pink following medium steaming. An immensely strong timber that outperforms oak for bending strength, stiffness and shear by some 20%. It is also stronger in resistance to impact loads. It works well, producing a good, smooth surface and stains and polishes to an excellent finish. Average weight 720kg/m³.

ACCLIMATISATION

IMPORTANT - You should note that acclimatising timber products by leaving in the room or a room with a similar humidity for at least 48 hours is essential if problems associated with shrinkage and expansion are to be avoided. Storing stair balustrading, for example, in a cold and damp garage for months and then using for immediate internal installation is not good trade practice. This is due to timber being a natural material that both absorbs and loses moisture. The rule of thumb to remember is 'timber plus water/moisture equals expansion' and 'timber plus heat equals shrinkage'. It is therefore extremely important to seal/finish your timber products once installed by painting, staining or varnishing (see page 28 for advice and ideas).